













Cover Rx assembly instructions

First inspect the included (2) hardware bags and all other parts (see figure 1) to make sure there is nothing missing

HARDWARE AND PARTS LIST:

- A  (2) of each - *attaches main body to pivot arm tabs*
- B    (2) total (*B and C are identical*) - *connects to air shock*
 C   (*B is Pre-installed*)
- D  (2) Pins
- E   (4) Screws + (2) Nuts - *attaches baseplate to support legs*
- F    (2) of each - *attaches main body to support legs*

G - (1) Gas Shock

H - (1) Base Plate

I - (2) Support Legs

J - (1) Pivot Arm

K - (1) Main Body

L - (2) Short U-Arm Elbows

M - (2) Long U-Arm Elbows

N - (2) U-Arm Spacers

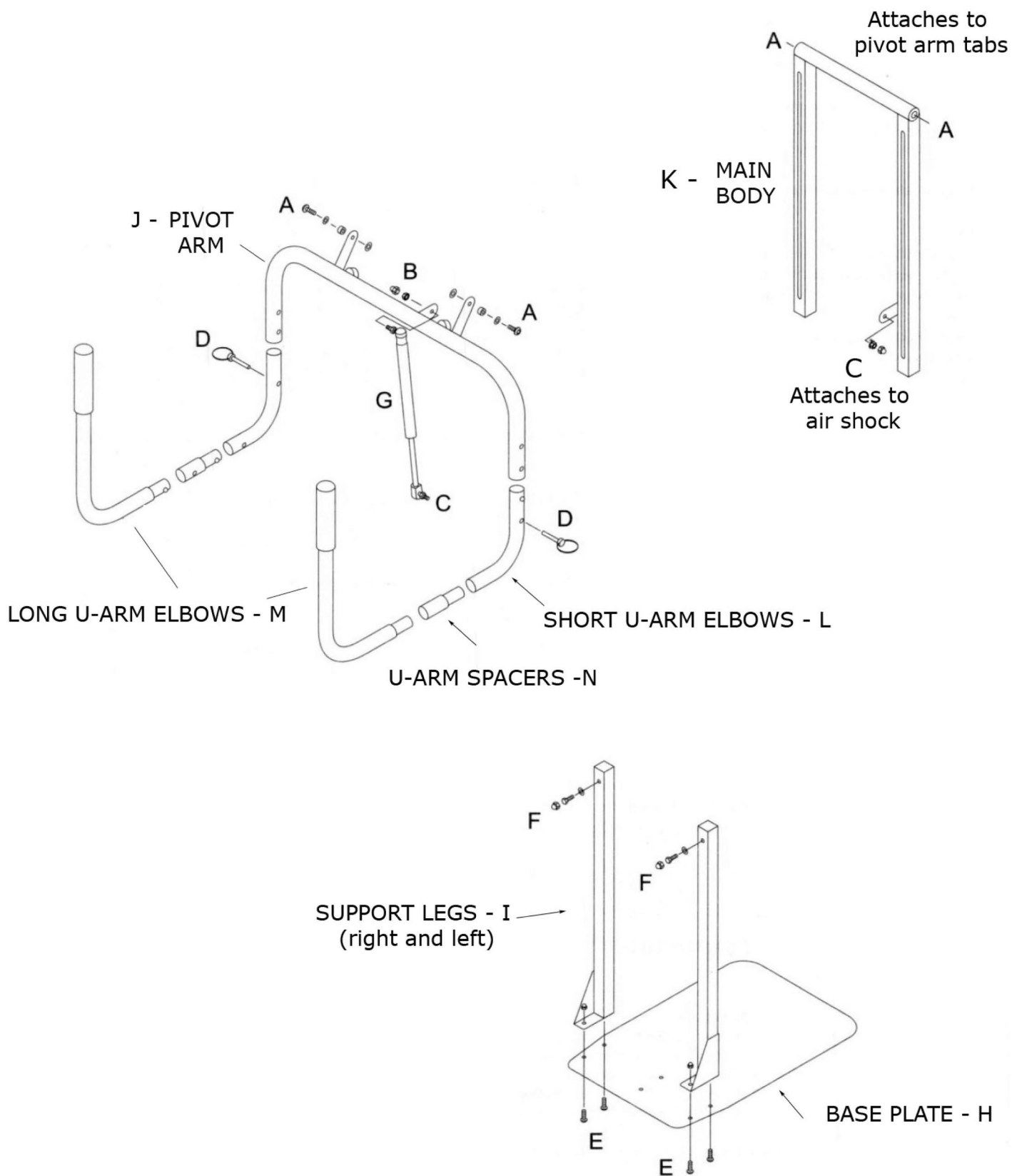
P - (2) Bumper Knobs

Video instructions available at
www.CoverValet.com

Also includes all tools needed
 box wrench and allen wrench

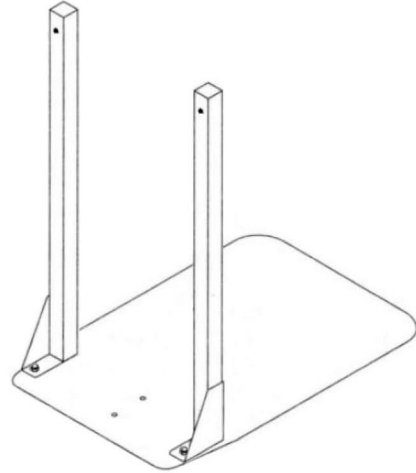
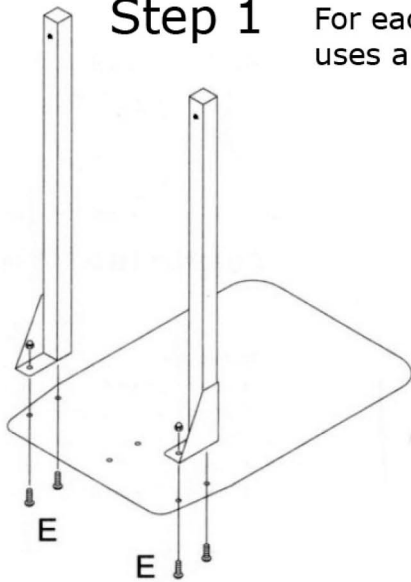


Figure 1 - Connection reference overview



Step 1

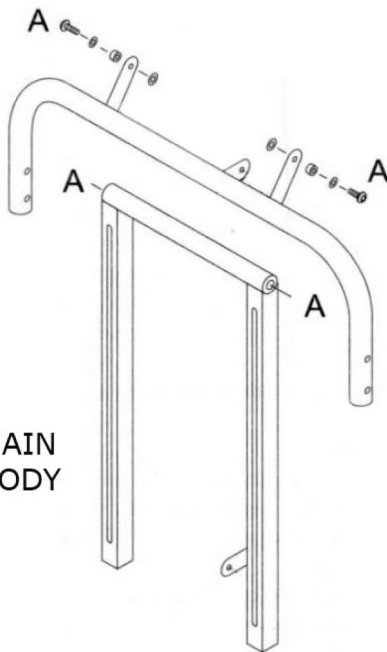
Attach base plate to support legs with 4 screws (E).
For each leg, one screw threads directly into leg and the other uses a rounded nut to secure. Set aside base assembly.



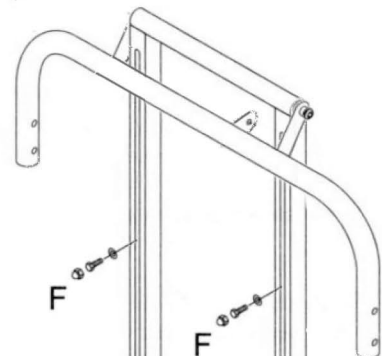
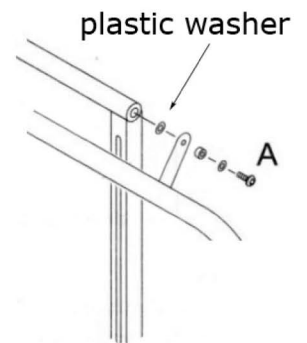
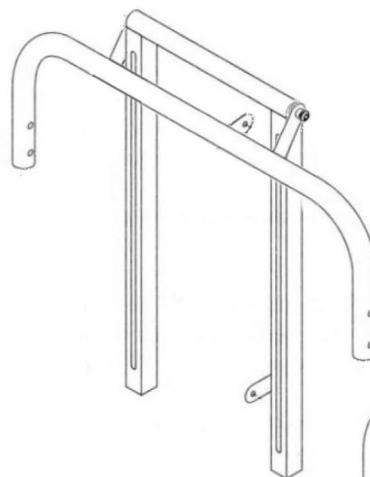
Step 2

Attach pivot arm to main body (A)

PIVOT
ARM



MAIN
BODY

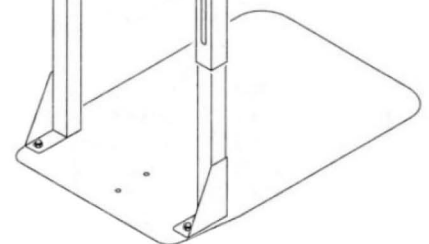


Step 3

Slide pivot arm/main body over support legs/main body.

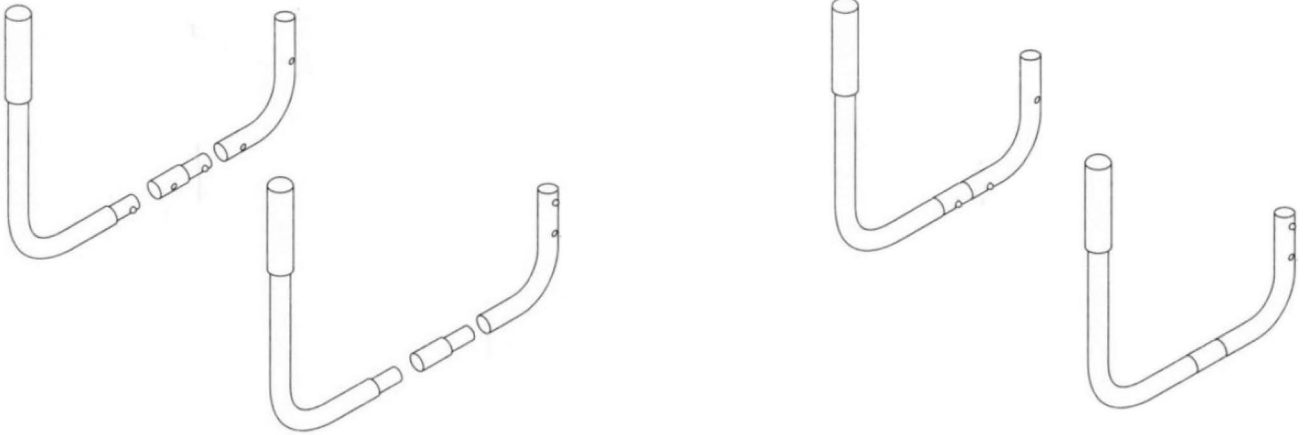
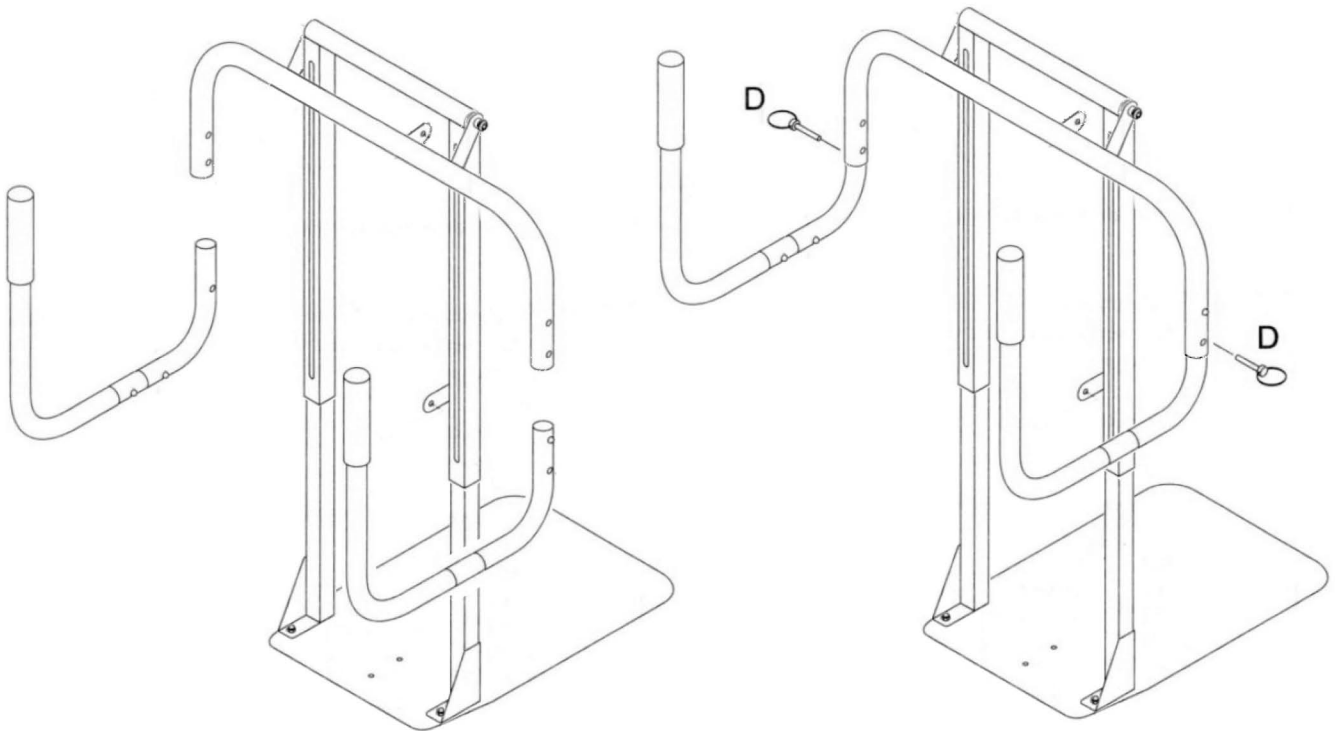
Insert screws (F) through channel in main body into hole near top of support legs.

Leave loose for now, they will be tightened later to adjust height.



Step 4

Assemble the U-arms. Use the included small spacer if your cover is above average thickness. If you do not need the spacer, remove it as it will cause unwanted "wobble."

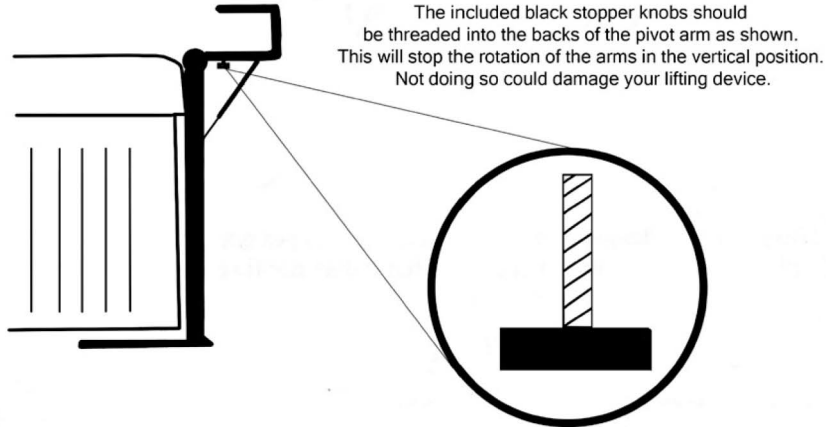
**Step 5** Slide U-Arms into pivot arm; align spring button so that it locks in place and insert pin all the way through hole and channel.**Step 6**

Attach the Ball stud with the lock nut to the tab on the right leg of the Main body. This ball stud should face the opposite direction as the pre-installed ball stud on the back of pivot arm.

Attach Gasshock to ball studs at C and B

Step 7

Install bumper knobs into pivot arm*



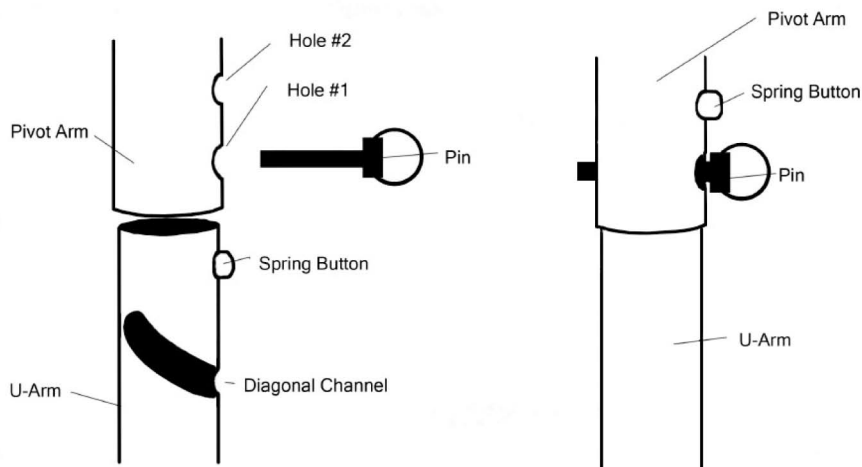
Step 8

Slide Sure lift (base Plate) under spa
Leave 1/2" of space between the Sure Lift and your spa

Step 9

Tighten all screws and adjust height (F)
The base of the U-arms should be flush with the top of the acrylic (see figure in step 7) to ensure an easy slide in to the lifter.

Figure 2 - Attaching U-arms to pivot arm (Step 5)



*The Spring Button on your U-arm should come through Hole #2

The included Pin should be pushed through Hole #1.
as well as the Diagonal Channel. This will allow you to depress the Spring Button and rotate the U-arms 90 degrees for a low profile against the spa when not in use.